

USER INFORMATION

ENGLISH
Rev. 23/06/2026

RAWBEAM 350

ULTRA BEAM

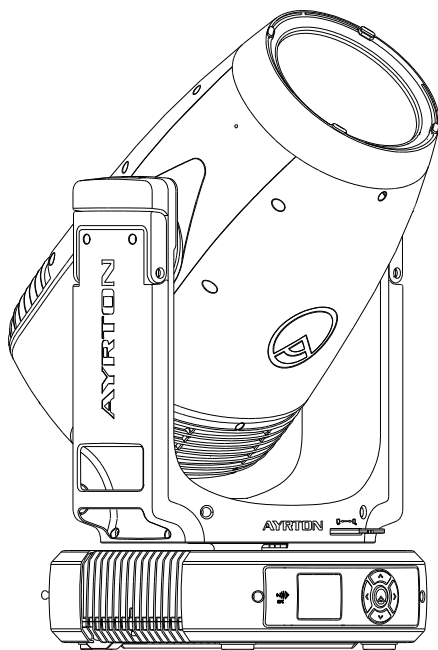

AYRTON

Digital Lighting



2 Rue de Vitruve,
91140 Villebon-sur-Yvette,
France

CONTENTS

1. SAFETY INSTRUCTIONS	3
2. FEATURES	4
3. GETTING STARTED	5
4. CONTROL AND FUNCTIONS	13

Keep this manual for future needs.

Errors and omissions for all information given in this user manual are possible.
All information is subject to change without prior notice.



1. SAFETY INSTRUCTIONS

1.1 > IMPORTANT SAFETY WARNINGS

This device has left the factory in perfect condition. In order to maintain this condition and to ensure safe operation, it is absolutely necessary for the user to follow the safety instructions and warning notes written in this user manual.

For safety reasons, please be aware that all modifications to the product are forbidden. We will not be liable for any damage or injury caused by installation, use, maintenance or service that not follow this manual.

In order to install, operate and maintain the lighting fixture safely and correctly we suggest that the installation and operation be carried out by qualified technicians and these instructions be carefully followed.

1.2 > PHOTOBIOLOGICAL SAFETY

The light source of this product is based on laser diodes. This product qualifies for the laser products safety standard IEC 60825-1:2014, edition 3, "part 4.4, Laser products designed to function as conventional lamps", under which it is classified as CLASS 1 LASER PRODUCT. Alternately evaluated under the standard IEC 62471-5:2015 "Photobiological safety of lamps and lamp systems", the photobiological risk classification is assigned as RISK GROUP 3 (RG3).



RISK GROUP 3



Caution! Possibly hazardous optical radiation emitted from this product. Do not look at operating lamp source. Eye injury may result.



RG3
Hazard distance: Refer to the manual.
Not for household use.
EN/IEC 62471-5

- **CAUTION! Use of controls or adjustments or performance of procedures other than those specified herein may result in hazardous radiation exposure.**
- The US Food and Drug Administration (FDA) requires that the owner of the product be a holder of a valid FDA CDRH laser light show variance and operate the product in accordance with the terms of the variance. (variance is a "permit" issued by FDA). It requires the operator (if not the owner) of the product to be a legal employee of the variance holder and to have completed a laser safety training course and an operators training course.
- The product is in excess of the Exempt Risk Group, the viewer-related risk is dependent upon how the user installs and uses the product.
- This product is in conformity with performance standards for laser products under 21 CFR 1040, except with respect to those characteristics authorized by Variance Number FDA-2023-V-1465 effective (September 27, 2023)
- The product is in excess of the Exempt Risk Group, the viewer-related risk is dependent upon how the user installs and uses the product.

- Operators shall control access to the beam within the hazard distance or install the product at the height that will prevent spectators' eyes from being within the hazard distance.
- Hazard Distance (HD) is the distance from the projector's nearest point of human access where the beam radiance or irradiance exceeds the applicable exposure limit.
- The operators shall control the product to prevent human exposure to the luminaire(s) light within the HD. Hazard distances (according to different settings):

US HD (United States Hazard Distance) = TBA
 Non US HD = 48.7 meters (157.48 feet).
 Hazard Distance (worst case) is measured at full power and narrowest beam angle for 0.25 seconds.
 However, do not illuminate personnel closer than this distance under any circumstances.

- Do not operate with personnel exposure shorter than the declared hazard distance due to risk of skin or corneal burns.
- This Laser Product is designated as Class 1 / RG3 during all procedures of operation.
- Internal (embedded) laser parameters:
- Laser Wavelengths: 445 - 455 nm.
- Laser Power max: 55 W (at light engine aperture).
- Beam Diameter: 26 mm.
- Divergence: 910 mrad.
- Emissions: 1.2 kHz, varying duty cycle: 0 - 97%.
- Luminaire Wavelengths: 445 nm - 700 nm.
- **CAUTION! The user must not modify the unit or remove protective covers or housings except as required for service. The laser product is never to be operated if the unit is defective or the cover or seal is damaged.**
- **Danger - class 4 laser light when open. Avoid eye or skin exposure to direct or scattered light.**
- No maintenance is required or allowed by the user.
- Service is only to be performed by trained and authorized personnel. Consult service manual for laser safety procedures before opening unit.
- As required by US state and federal OSHA requirements, maintenance and service is to be performed under the terms of ANSI Z136.1, "Safe Use of Lasers". Wear laser safety eyewear when servicing the unit.
- All laser light shows shall be under the direct and personal control of trained, competent operator(s). The operator(s) shall:
 - Be an employee of the variance holder who will be responsible for the training and the conduct of the operator.
 - Be located where all beam paths can be directly observed at all times.
 - Immediately terminate the emission of light show radiation in the event of any unsafe condition; or for outdoor shows, upon request by any air traffic control officials.
- Hazard distances (HD) for all relevant viewer-related risk groups below RG3: Not Applicable. In no case expose personnel closer than the Hazard Distance indicated above.
- According to IEC62471-5 hazard distances (depending on settings): HD = 48.7 m. @ Minimum angle.







CAUTION



High voltage. Risk of severe or fatal electric shock.



Always disconnect mains supply before removing any fixture covers.

	Never touch the device during operation. covers may be hot.
	Fixture exposed to salt water should not be stored in its foam insert without being cleaned with fresh water first. It is best practice that fixture be stored dry.
	Never look directly into the light source.
	Light collimation system This product contains internal light collimation system. Avoid intense light from any angle.
	Not suitable for household illumination.
	Not for residential use.
	Disposing. This product is supplied in compliance with european directive 2012/19/EU - Waste Electrical and Electronic Equipment (WEEE). To preserve the environment please dispose / recycle this product at the end of its life according to the local regulation.



Warning: Changes or modifications to this unit not expressly approved by the party responsible for compliance could void the user's authority to operate the equipment.

Note: This equipment has been tested and found to comply with the limits for a class a digital device, pursuant to part 15 of the fcc rules. These limits are designed to provide reasonable protection against harmful interference when the equipment is operated in a commercial environment. This equipment generates, uses and can radiate radio frequency energy and, if not installed and used in accordance with the instruction manual, may cause harmful interference to radio communications. Operation of this equipment in a residential area is likely to cause harmful interference in which case the user will be required to correct the interference at his own expense.

1.3 > GENERAL GUIDELINES

Damage caused by the disregard of this user manual is not subject to warranty. The dealer and manufacturer will not accept liability for any resulting defects or problems.

- Under no circumstances should the fixture be pointed at the sun. Sunlight, combined with the high efficiency lenses used in the product can cause significant damage to the fixture.
- Be aware that even when lens is not pointed directly at the sun damage may occur. It is best practice to ensure that the lens is pointed away from the sun, preferably in the opposite direction.
- Always dry and clean your fixture before storing it for any length of time.
- Never use any abrasive cleaning products on the fixture as this may damage the coating of the fixture impacting its anti-

corrosion protection.

- This product is intended for the following applications: trade show or convention, indoor arena, outdoor arena, outdoor unenclosed arena, stage, studio, theater, event, venues, theme parks, architecture and similar applications.
- If the device has been exposed to temperature changes due to environmental conditions, do not power on immediately. The resulting condensation could damage the device. Leave the device powered off until it has reached room temperature.
- Ensure the sealing rubber covers of powerCON and XLR connectors are fitted properly when the device is not in use, to avoid water ingress.
- This device falls under protection-class I. Therefore, it is essential that the device be earthed.
- If either lenses or display are damaged (damage may include cracks or gashes in the material) they must be replaced.
- Electrical connections, such as replacing the power plug, must be performed by a qualified person.
- Make sure that the available voltage is not higher than that which is stated in this manual.
- Make sure the power cord is never crushed or damaged by sharp edges. If this should be the case, replacement of the cable must be done by an authorized dealer.
- If the external flexible power cord of this device is damaged, it shall be exclusively replaced by the manufacturer or their service agent or a similar qualified person in order to avoid injury.
- When the device is not in use or before performing maintenance or service, always disconnect the device from the mains. Only handle the power cord from the plug. Never pull the plug out of a socket by tugging the power cord.
- When powered on for the first time, some smoke or smell may occur. This is caused by coating on metal parts when heated and is normal. If you are concerned, please contact your distributor.
- Do not focus the beam onto flammable surfaces. The minimum distance between the exiting lens of the device and the illuminated surface must be min. 25 m. The minimum distance from fixture head to combustible materials must be min. 0.1 m. (for personnel exposure distances, refer to the above mentioned Hazard Distances).
- The projection system shall be securely mounted or immobilized to prevent unintended movement or misalignment. Beam masking will be provided as an inherent part of the system design to prevent overfilling of screens, beam stops, targets, etc.
- This fixture is only allowed to be operated within the maximum alternating current as stated in the technical specifications in section 2 of this manual.
- Handle the device with care, avoid shaking or using force when installing or maintaining the device.
- If you use the quick lock cam when rigging the device, make sure the quick lock fasteners are located in the quick lock holes correctly and securely.
- Operate the device only after having familiarized yourself with its functions. Do not permit operation by persons not qualified for operating the device. Most damage is the result of unprofessional operation.
- Please use the original packaging if the device is to be transported.
- The applicable temperature for the device is between -20 °C and 45 °C. Do not use the device outside of this temperature range. (Note: When the temperature detected by laser source between -20 °C and 0 °C, the fixture needs to wait for the heater to increase the internal temperature to be above 0 °C before illumination will occur).

2. FEATURES

POWER SUPPLY

- AC100-240 V~, 50/60 Hz
- Power: 660 W maximum

OPTICS

- Beam Mode: 11" to 18"

- Spot Mode: 3° to 45°
- Fast motorised linear zoom

LIGHT SOURCE

- Laser 350 W, White
- Rated life (L70): up to 12,000 hours

MOVEMENT

- Highly accurate positioning; moving-head operated via either 8- or 16-bit resolution
- Pan and tilt automatic repositioning
- Moving-head range: infinite pan and tilt rotation

COLOURS

- Sophisticated colour mixing system providing CMY color mixing
- Variable CTO colour temperature correction
- Fixed colour wheel with 16 colour filters and one color animation section

GOBOS

- One indexable rotating gobo wheels with 10 glass gobos, plus open position
- Adjustable-speed rotating gobo in both directions
- Fixed gobo wheel with instant access to 30 metal gobos

FROST

- 2 frost filters: one light, one heavy

EFFECTS

- Monochromatic graphical animation effects wheel with continuous rotation in both directions
- 6 combinable rotating and indexable prisms

DIMMER / STROBE

- Electronic dimmer, allowing perfect light adjustment from 0 to 100% without colour variation
- Strobe effect: 1 to 25 flashes per second

SOFTWARE FEATURES

- Local DMX addressing and optional parameters through its built-in LCD control panel
- Remote DMX addressing and optional parameters through a standard RDM DMX controller
- Information menu including hour counter, temperature, software version

HARDWARE FEATURES

- Graphic LCD display for addressing and special functions settings, with flip function
- 5 menu buttons to set functions
- Integrated wireless CRMx TiMo RDM receiver from LumenRadio™
- IP65 XLR-5 pin male and female connectors for DMX connection
- IP65 RJ45 IN / OUT connectors for ArtNet connection
- IP65 power connector for power connection

CONTROL

- DMX 512 protocol, through DMX cable or a wireless system
- DMX-RDM compatible
- ArtNet & sACN protocol through Ethernet cable
- Local control panel, with IP65 LCD display
- DMX mode (43 DMX channels)

COOLING SYSTEM

- Advanced liquid cooling system
- Self-adjusting variable speed fans for quiet operation (Auto mode)
- Selectable ventilation user modes with a new Silent Mode
- Safety protection against excess temperature

HOUSING

- IP65 protection rating (IP66 optional)

INSTALLATION

- 2 Omega ¼ turn brackets
- 4 ¼ turn mounting points
- Safety cable attachment point

OPERATING PARAMETERS

- Operating positions: all (device on floor or fixed to a support)
- Maximum permitted: 45°C (113°F)
- Minimum permitted: -20°C (-4°F)
- Minimum usage distance: 20 m (65.62 ft)

COMPLIANCE

- CE, UKCA, ETL

SIZE

- Product: 339 x 297 x 592 mm (l x h x d)
- Foam: 395 x 630 x 335 mm (l x h x d)

WEIGHT

- Product: 25.4 kg

3. GETTING STARTED

3.1 › UNPACKING

After unpacking, you will find the following items in the package:

- RAWBEAM 350 fixture 1
- User Information manual 1
- Power Cable 1
- Omega Bracket 2

3.2 › PLACEMENT OF LABELS

Please check and read carefully the labels on the fixture before using:

Warning!
Possibly hazardous optical radiation emitted from this product. Do not look at operating lamp source. Eye injury may result.

RG3
Hazard Distance: Refer to the manual
Groupes de Risque 3

Attention:
ce produit peut émettre un rayonnement lumineux nocif. Ne regardez pas la source en fonctionnement.
Des blessures oculaires peuvent en résulter.

CAUTION! Risk of electric shock, disconnect input power before opening.
PRENDRE SOIN: Risque de choc électrique, déconnecter l'alimentation avant d'ouvrir.
Warning: This apparatus must be earthed.
Avertissement: Cet appareil doit être relié à la terre.

CAUTION! A fixture equipped with self water should not be stored in its foam insert without being cleaned with fresh water first. It is best practice that fixture be stored dry.

Maximum temperature of the external surface 80°C
Minimum distance to illuminated surface = (-20.0 in) (retroved zoom with followup)
Minimum distance from fixture head to combustible materials = 0.1m.
Distance minimum à surface éclairée = (-20.0 in) (zoom minimum à photopapier)
Distance minimum de la tête de l'appareil aux matériaux combustibles = 0.1m.

AYRTON
2 rue Vitruve 91140
Villabon-sur-Yvette, France
Model: RAWBEAM 350
Place of MFG: Haoyang

This product is in conformity with performance standards for laser products under 21 CFR 1040, except with respect to those characteristics authorized by Variance Number FDA-2023-V-1465 effective on September 27, 2023.

Date of manufacture: Month/year

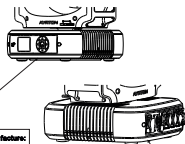

CONFORME TO CE 2014 WITH CERTIFICATION TO CE MARKING BY THE NATIONAL AUTHORITY FOR THE PROTECTION OF INDUSTRIAL DESIGN

THIS DEVICE COMPLIES WITH PART 18 OF THE FCC RULES. Operation is limited to the following two conditions: (1) This device may not cause harmful interference, and (2) This device must accept any interference received, including interference that may cause undesired operation.

Trade Name: AYRTON
Model Number: RAWBEAM 350
CAN ICES-3(A)/NMB-3(A)

FC

SCAN FOR SUPPORT

Designed by AYRTON in France, Made in China | IP65 | www.ayrton.eu

AYRTON 848,2 Rue Vitruve, 91140 Villabon-sur-Yvette, France | contact@ayrton.eu | +33(0)168701800

3.3 > FIXTURE OVERVIEW

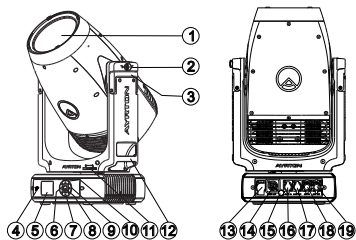

- | | | |
|----------------|------------------|--------------|
| 1. Front Lens | 8. Center-button | 15. Valve |
| 2. Tilt Lock | 9. Right-button | 16. RJ45 In |
| 3. Handle | 10. Up-button | 17. RJ45 Out |
| 4. NFC | 11. Pan lock | 18. DMX In |
| 5. Display | 12. Handle | 19. DMX Out |
| 6. Left-button | 13. Power In | |
| 7. Down-button | 14. Power Out | |

- Never stand directly below the device when mounting, removing or servicing the fixture.
- The operator has to make sure the safety relating and machine technical installations are approved by an expert before taking the device into operation for the first time.
- These installations have to be approved by a skilled person once a year.

RIGGING USING THE OMEGA BRACKETS

- Fix the clamp to the bracket by tightening the M12 nut and bolt to the bracket through the $\Phi 13$ hole in the middle of the bracket.
- Insert the quick-lock fasteners of the first Omega holder into the respective holes on the bottom of the device. Tighten the quick-lock fasteners fully clockwise.
- Install the second Omega holder.
- Pull the safety cable through the holes on the bottom of the base and over the trussing system or another suitable rigging point. Insert the end into the carabiner and tighten the safety screw.

CAUTION

This step is very important to ensure safe rigging of the fixture.

3.4 > UNLOCK THE PAN AND TILT BEFORE USING

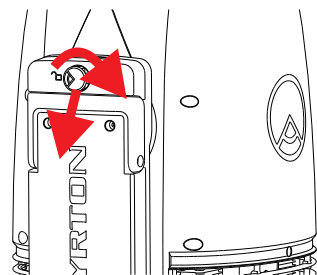

Release the Tilt lock by pulling it out and turn 90°.

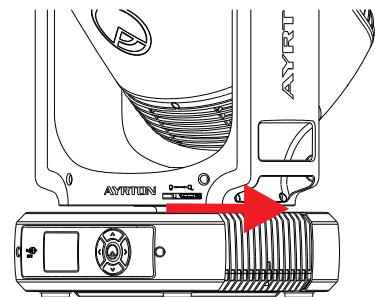

Release the Pan lock by pulling it to the right side.

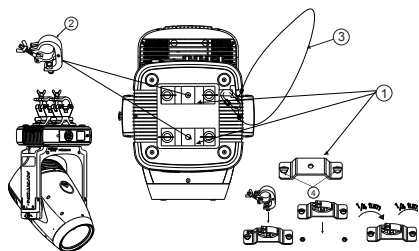

- | | |
|------------------|------------------------|
| 1. Omega bracket | 3. Safety rope |
| 2. Clamp | 4. Quick-lock fastener |

RIGGING DRAWINGS

The fixtures can be installed by sitting on floor, hanging on truss upside down (on ceiling) or hanging vertically (on wall), as shown on the drawing below:

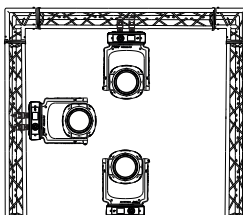

3.5 > INSTALLATION INSTRUCTIONS - RIGGING THE FIXTURES

CAUTION

Please consider the respective national norms during the installation. the installation must only be carried out by a qualified person.

- The installation of the effect has to be built and constructed in a way that it can hold 10 times the weight for 1 hour without any harming deformation.
- The installation must always be secured with a secondary safety attachment, e.g. an appropriate safety rope.

- Be sure this fixture is kept at least 0.1m away from any flammable materials (decoration etc.).
- Always use and install a safety cable as a safety measure to prevent accidental damage and/or injury in the event the clamp fails.
- **WARNING! Always use and install original Ayrton accessories to ensure a safe installations and use of the unit. Ayrton WILL NOT be responsible for the use of third party accessories.**
- Rig the projector high enough to provide clearance for people who may walk beneath the beam path or establishing a restricted access area that extends beyond the beam hazard distance.
- **WARNING! Please DO NOT let other external intense lights to shine through the fixture front lens, it may cause significant internal damages!**

- When install fixture outdoor at day time (with power off), please make sure that the fixture front lens is NOT facing the sun.
- When use fixture outdoor at day time (with power on), please avoid fixture front lens facing the sun.
- When fixture is on standby outdoor at day time (with power ON and no DMX signal), please make sure the "sun protection" mode is ON (default).

3.6 > CONNECTIONS – CONNECTING POWER AND SIGNAL CABLES

POWER CONNECTION

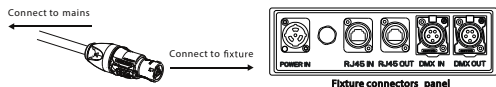

- Connect the power cable to the "Power In" socket of the fixture: Insert the power cable connector and turn clockwise until it clicks to lock.
- Connect the power cable plug to the mains: AC100-240 V-, 50/60 Hz, Power 660 W.

DMX-512 / ART-NET CONTROL CONNECTION

Connect the provided male side of the XLR cable to the female XLR output of your controller and the female side of the XLR cable to the male XLR input of the device. You can connect multiple devices together in a serial fashion. The cable needed should be two core, screened cable with XLR input and output connectors. Up to 32 fixtures can be connected on a serial DMX link, Please refer to the diagram below.

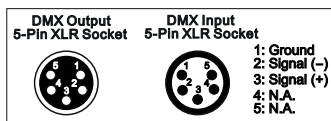
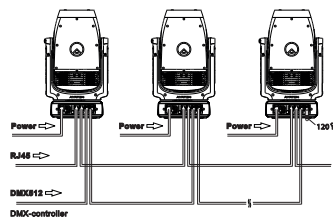

DMX-512 CONNECTION WITH DMX TERMINATOR

For installations where the DMX cable has to run over a long distance or is in an electrically noisy environment, such as in a discotheque, it is recommended to use a DMX terminator. This helps in preventing corruption of the digital control signal caused by electrical noise. The DMX terminator is an XLR plug with a 120 Ω 0.25 Watt resistor connected between pins 2 and 3, which is then plugged into the output (female) XLR socket of the last fixture in the chain. Please see illustrations below

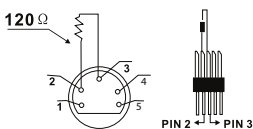

Note: If the link is divided into branches using a DMX splitter, terminate each branch of the link.

DEVICE DMX START ADDRESS SETTING

All fixtures should be given a DMX starting address when using a DMX signal, so that the correct fixture responds to the correct control signals. This digital starting address is the channel number from which the fixture starts to "listen" to the digital control information sent out from the DMX controller. The allocation of this starting address is achieved by setting the correct address number on the display located on the base of the device. You can set the same starting address for all fixtures or a group of fixtures, or set different addresses for each fixture individually.

If you set the same address on all devices, all the devices will start to "listen" to the same control signal from the same channel number. In other words, changing the settings of one channel will affect all the fixtures simultaneously.

If you set a different address, each unit will start to "listen" to the channel number you have set, based on the quantity of control channels of the unit. That means changing the settings of one channel will affect only the selected device.

In the case of the moving head, in 43 channel mode, you should set the starting address of the first unit to 1, the second unit to 44 (43 + 1), the third unit to 87(43+44), and so on.

3.7 > OPERATING INSTRUCTIONS OF THE INTERNAL DMX WIRELESS SYSTEM

EQUIPMENT

This product is equipped with a Lumen radio Timo DMX receiver

MESSAGE FROM THE LED INDICATOR

- Solid Green: Logged on to a transmitter and actively receiving DMX data.
- Solid Red: Not logged on to any transmitter (available) or not receiving DMX data.

W-DMX IN THE FIXTURE MENU

In the shortcut menu, you'll find the option "Unlink W-DMX". Selecting this will disconnect the fixture from its current transmitter.

SETTING UP THE WIRELESS SYSTEM

To connect the fixture to a transmitter, the transmitter must be in pairing mode.

You can activate this mode by selecting "Unlink W-DMX" from the fixture's menu or by performing a factory reset on the fixture.

Once the transmitter is ready, press its pairing button to link the devices.

Important Notes:

- After each job, please log out all receivers from the transmitter. This ensures the receivers return to an unassigned state and are ready for future pairings.
- Do not connect a fixture that is wirelessly linked to a transmitter to a DMX controller via cable. Doing so may cause signal interference.

3.8 > DISPLAY SETTINGS OPERATION

The fixture offers LCD Display and Buttons for setting display menus, you can use the buttons to set or check the Address, Mode, Operations, Test, Info and Preset menus.

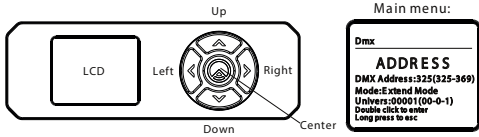

Center button	Double click to activate display, or confirm setting, or go into submenu; Long pressing 2s on main menu to access the shortcut menus; Long pressing 2s on submenu to exit or go back to previous menu.
Left button	Click to go left to other submenu
Right button	Click to go right to other submenu.
Up button	Click to go up to other submenu, or increase the setting values.
Down button	Click to go down to other submenu, or decrease the setting values.

After accessing the submenu in edit mode, if no operation, it will automatically exit to the main menu after 15 seconds from the last button operation. When the fixture is powered on and the signal is connected, after 5 minutes, the display will switch off automatically.

USING THE DISPLAY MENUS

Double click to activate display, then on the main menu double click to enter into the following menus, click the up button or down button to browse and select the desired menus:



ADDRESS	To set the DMX address.
MODE	To set the user mode.
OPTIONS	To set the status setting, fan control, signal, dimming curve and others.
INFO	To check the time, software version, fan info and others.
TEST	To reset the fixture, do the calibration and others.
PRESET	To edit prog. and scenes.

DEFAULT SETTINGS SHADED

Address		
Address	DMX Address: 001-XXX Decimal Address: XXXXX Net: XX Sub-Net: X Universe: X Signal: DMX/WDMX/Art-Net/sACN	DMX address setting
Mode		
User Mode	Extend Mode User Mode A User Mode B User Mode C	User's mode to change channel numbers
Edit User ModeA;	Max channel PAN	Preset User modes A,B,C

Options			
Status	No DMX Mode	Close/Hold/Auto	Hold if no DMX
	Sun Protection	ON/OFF	Sun protection movement
	Pan Reverse	ON/OFF	Pan Reverse movement
	Tilt Reverse	ON/OFF	Tilt Reverse movement
	Pan Degree	630/340/360SC	Pan Degree Select
	Tilt Degree	270/540/360SC	Tilt Degree
	Feedback	ON/OFF	Movement Feedback
	Init PAN	ON/OFF	Init PAN
	Init TILT	ON/OFF	Init TILT
	Prerig INIT	ON/OFF	Prerig INIT
	Reset Mode	Fast/All Rot Gobos	Reset Mode
	Pan/Tilt Spd	Fast/Medium/Slow/FS Mode/Tracking 360	Movement Speed
	CMY Spd	Fast/Medium/Slow	CMY Spd
	CMY Path	Shortcut/Spinout	CMY Path
	Zoom/Focus Spd	Fast/Medium/Slow	Zoom/Focus Spd
Reset Dim Fade	ON/OFF	Reset Dim Fade	
Hibernation	OFF, 01M-99M	Stand by Mode	
DMX Output	ON/OFF	Ethernet to DMX	
Data Collect	Agree/Disagree	Data Collect	
4G/Wifi	4G/Wifi	4G/Wifi	
Wifi Info	No/Yes	Wifi Info	
Service PIN	Service PIN	Password = XXX	Service Password="050"
	Set IP	xxx.xxx.xxx.xxx	Set IP
	Set Mask IP	xxx.xxx.xxx.xxx	Set Mask IP
	Reset From Mac	ON/OFF	Reset From Mac
	DHCP	ON/OFF	DHCP
	lot Lock Enable	ON/OFF	lot Lock Enable
	Cross Load SW	ON/OFF	Cross Load SW
	Clr Error Info	ON/OFF	Clr Error Info
Threshold Dect	Low/Middle/High	Threshold Dect	
Fans Control	Fans Speed	Auto Stage Silence Super Silence	Fans Speed select
	Constant Fans	ON/OFF	Constant Fans
Disp.Setting	Shutoff Time	02-60m 05m	Display shutoff time
	Flip Display	ON/OFF	Reverse 180 degree
	Key Lock	ON/OFF	Key Lock
	DispFlash	ON/OFF	DispFlash
Temp. C/F	Celsius Fahrenheit	Temperature switch between " C / F	
Initial Pos.	PAN =XXX	Initial effect position	
Dim Curve	Square Low Linear	Dim Curve	
Refresh Select	12K 2.4K 16K 25K	Refresh Select	
Defog	OFF Auto ON	Defog	
Reset P/T Fade	ON/OFF		
Illumination Limit	20 m Distance/15 m Distance/10 m Distance		
Trigger	DMX Value Disp. Set to Follower Auto Program	PAN... Follower 1, Follower 2, Follower 3 Leader/Alone	
Reset Default	ON/OFF		
Reset Options	ON/OFF		

Options		
Reset User Set	Address	DMX address: 001-XXX Decimal Universe: XXXXX Net: XX Sub-Net: X Universe: X Signal: DMX/WDMX/Art-Net/sACN Encoder Select Photoelectric/Magnet
	Mode	Extend Mode User Mode A User Mode B User Mode C
	Fans Speed	Auto Stage Silence Super Silence
	Constant Fans	ON/OFF

Info		
Time Info.	Current Time	XXXX (Hours)
	Ttl Life Hrs	XXXX (Hours)
	Last Run Hrs	XXXX (Hours)
	Laser Hours	XXXX (Hours)
	Current SW Hrs	XXXX (Hours)
	Timer PIN	Password=XXXX
	Clr Last Run	ON/OFF

Temp. Info	Temp.	L:XXX °C/°F Max: XXX °C/°F Min: XXX °C/°F
		B:XXX °C/°F Max: XXX °C/°F Min: XXX °C/°F
		H:XXX °C/°F Max: XXX °C/°F Min: XXX °C/°F
	Reset Temp.	

Humidity	x%	Humidity Information
----------	----	----------------------

Fan Info.	xxxx RPM	Fan Information
-----------	----------	-----------------

Software Ver	V1.0....	Software version
--------------	----------	------------------

Signal Quality	xxx	Signal Quality
----------------	-----	----------------

Network	IP, Mask, Mac	Network
---------	---------------	---------

Error Info.	Error Record 1	Error Info.
-------------	----------------	-------------

Blackout Info	Left.....	Blackout Info
---------------	-----------	---------------

SN	Product: xxxxx... LASER: xxxxx...	SN
----	--------------------------------------	----

RDM UID	UID: xxx-xxxxxxx	RDM UID
---------	------------------	---------

Test		
------	--	--

Home	All	Reset All
	Pan&Tilt	Reset Pan&Tilt
	Colour	Reset Color
	Gobo	Reset Gobo
Test Channel	PAN	Test function

Manual Ctrl.	PAN =XXX	Fine adjustment of the lamp
--------------	----------	-----------------------------

Calibration	-Password-	Password "050" Calibrate and adjust the effects to standard/right position
	PAN	

CMY Comp	Service PIN C M	CMY Comp
----------	-----------------------	----------

Gobo Replace	Gobo Wheel 1	Gobo Replace
--------------	--------------	--------------

Preset			
Select Prog.	Prog. Part 1 = Program 1 ~ 10	Program 1	Select programs to be run
	Prog. Part 2 = Program 1 ~ 10	Program 2	
	Prog. Part 3 = Program 1 ~ 10	Program 3	
Edit Prog.	Program 1	Program Test	Testing program
	Program 10	Step 01=SCxxx Step 64=SCxxx	
Edit Scenes	Edit Scene 001	Pan,Tilt,.... --Fade Time-- --Scene Time-- Input By Outside	Save and automatically return manual scenes edit
	~ Edit Scene 250		
Scenes Input	XX-XX		Scenes Input

3.7.1 Address

Address

With this function, you can adjust the DMX address, the Universe and the selection of the control signal

3.7.2 Mode

User Mode

With this function, you can choose user defined channel orders.

Edit User Mode

With this function, you can edit user defined channel orders of User Mode A/B/C

3.7.3 Options

Status

No DMX Status

With this function, you can choose the unit behavior in case no signal is detected between Close (all dmx value to 0), Hold (keep the last dmx value), and Auto (start auto mode).

Sun Protection

When this function is activated, the unit will automatically tilt down its head toward the ground when no signal is detected.

Pan Reverse

With this function you can reverse the Pan-movement.

Tilt Reverse

With this function, you can reverse the Tilt-movement.

Pan Degree

With this function, you can select Pan degree between 360SC, 630 or 540.

Tilt Degree

With this function, you can select Tilt degree for 360SC, 270 or 540.

360SC

This mode limits the total range of movement (pan or tilt) to a maximum of 360°. Since the fixture supports continuous rotation, it automatically selects the shortcut (SC) or fastest path between two position commands. For example, if transitioning from a pan position of 359° to 4°, the fixture will take the direct route, preventing unnecessary flips or spinouts.

Feedback

This function allows you to activate or deactivate the automatic repositioning of the Pan & Tilt in case of an accidental/manual move of the yoke.

Init PAN

This function allows you to deactivate the Pan movement.

Init TILT

This function allows you to deactivate the Tilt movement.

Prerig INIT

Allows you to activate a special init process: Pan init then Tilt init process when unit is used in prerig trusses

Reset Mode

This function allows you to choose the reset process for the gobo.

- **Fast:** The fixture only check the direction of the first gobo
- **All Rot Gobo:** The fixture is checking all the position of each gobo to make sure all the gobo are in the same position (Useful if using a custom Gobo)

Pan/Tilt Spd

With this function, you can select Pan & Tilt speed from "Fast", "Medium", "Slow", "FS Mode" and "Tracking 360".

CMY Spd

With this function, you can select CMY speed from "Fast", "Medium", "Slow".

CMY Path

This function allows you to choose between **Shortcut** and **Spinout** modes, which determine how the colour filter reacts to a command.

- **Shortcut:** The colour filter takes the shortest route to the target colour in snap command (Os). The shortest route could take a filter from 70% saturation past 100% saturation to get to open white. A fade time above 0s will cause the filter to behave like spinout mode.
- **Spinout:** The colour filter transitions smoothly by either increasing or decreasing saturation but never passes through open white to reach another colour.

Zoom/Focus Spd

With this function, you can select Focus speed from "Fast", "Medium", "Slow".

Reset Dim Fade

Allows the Light output to fade out and in during the reset process.

Hibernation: Standby mode

The device and stepper motors will be powered off if the unit stays without DMX signal for the User defined times (in Minutes). The fixture will perform a reset sequence once DMX is back.

DMX Output

With this function, the unit can transmit the signal received via WDMX or ArtNet/sACN through the DMX output.

Data Collect

With this Function, you can activate the collection of data information for the IoT. (The optional board is needed to use this option).

4G/Wifi

With this function, you can select between Wifi or 4G.

Wifi Info

This feature allows you to view the WiFi status and disconnect the current network using the "Clear" option.

Service PIN**Password**

The Password for this function is "050".

Set IP

This function allows you to set the IP of the Unit.

Set Mask IP

This function allows you to set the IP Mask of the Unit.

Reset From Mac

This function allows you to enable or disable the DHCP.

DHCP

This function allows you to enable or disable the DHCP.

lot Lock Enable

Enable or Disable the lot Lock function (The optional board is needed to use this option).

Cross Load SW

This function allows you to upload the current SW version to other units using a DMX connection. Do not disconnect the units before the process is done.

Clr Error Info

This function allows you to clear the error info list.

Threshold Detect

This function allows you to set different levels of movement detection for FDA Safety.

When Pan or Tilt are forced from their current position, or do not arrive at their programmed position.

- **Low:** Initial level of detection
- **Mid:** Increase by 25%
- **High:** Increase by 50%

Fans Control**Fans Speed**

With this function, you can set the fans speed. Settings are Auto, Stage, Silence, and Super Silence.

- **Auto:** The LASER module delivers **high** output and the fans ramp up and down depending on the ambient temperature and the temperature of the LASER module itself.
- **Stage:** The LASER module delivers **full** output and the fans remain at full speed regardless of the temperature of the LASER module.
- **Silence:** The LASER module is limited to **medium** output and the fans rotate at a slower speed.
- **Super Silence:** The LASER module is limited to a **lower** output and the fans rotate at the slowest speed.

For specific output details, refer to photometry document.

Constant Fans

Enables you to set the fans to run continuously, even when the LASER is off.

Disp. Setting**Shut off Time**

With this function, you can select the delay before the LCD display turns off. Choose between 2 to 60 minutes. The default is 5 minutes.

Flip Display

With this function you can rotate the display by 180° (when the unit is rigged)

Key Lock

With this function you can activate the automatic key lock function. If this function is activated, the keys will be locked automatically after exiting the edit mode for 15 seconds. keeping press the <MODE/ESC> key for 3seconds if you do not need this function.

DispFlash

With this function activated, display will flash if no signal is detected.

Temperature C/F

With this function you can display the temperature in Celsius or Fahrenheit.

Initial Pos.

With this function you can display initial effect position.

Dim Curve

With this function you can select the Dimmer Curve.

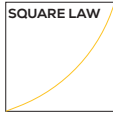
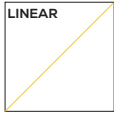

Refresh Select

With this function you can select the PWM rate.

- **1.2K & 2.4K:** provides superior dimming quality, especially for smooth fadeouts at lower levels.
- **16K & 25K:** are ideal for broadcast use.

Defog

This function allows you to set the defog mode as follows:

- **ON:** Activates the defog fan (excluding the LASER module cooling fans), sets the dimmer to full, and zoom to minimum. This function should only be used when necessary.
- **AUTO:** Activates the defog fan (excluding the LASER module cooling fans) when temperature and humidity reach a certain level. Zoom and dimmer are not affected.
- **OFF:** No defogging actions are performed, the defog fan will not rotate and the heaters are turned off.

If ON or AUTO are selected, the heater plate will turn on when the unit is powered on, the Heater will turn on and off as necessary to maintain a constant internal temperature of 45 °C.

Reset P/T Fade

This function allows you to choose the reset speed of the pan/tilt motors to avoid fast movement.

Illumination Limit

With this function, you can select different Illumination Limit, the power is limited to make the limit lower.

Trigger

DMX Value Disp.

With this function you can display the DMX 512 value of each channel. The display automatically shows the channel with a value changing.

Set to Follower

With this function, you can define the device as follower.

Auto Program

With this function, you can run the internal program. You can select the desired program under "**Select program**". You can set the number of steps under "**Edit program**". You can edit the individual scenes under "**Edit scenes**". With this function, you can run the individual scenes either automatically, i.e. with the adjusted Step-Time.

Reset Default

With this function, you can restore default setting (highlighted value in the above chart).

Reset Option

This function restores only the altered options settings (highlighted values in the chart above) to their default state.

Reset User Set

With this function, you can define the following "restore user" values:

- Address
- Mode
- Fans Speed
- Constant Fans

3.7.4 Info

Time Info

Current Time

With this function, you can display the temporary running time of the device from the last power on. The display shows "XXXX", "XXXX" stands for the number of hours. The counter is reset after turning the device off.

Ttl Life Hrs

With this function, you can display the running time of the device. The display shows "XXXX", "XXXX" stands for the number of hours.

Last Run Hrs

With this function, you can display last the running time of the device. The display shows "XXXX", "XXXX" stands for the number of hours.

LASER Hours

With this function, you can display the time of LASER. The display shows "XXXX", "XXXX" stands for the time of LASER.

Current SW Hrs

With this function, you can read the software running time of the device. The display shows "XXXX", "XXXX" stands for the number of hours.

Timer PIN

With this function, you can display the timer password.

Clr Last Run

With this function, you can clear last run time of the fixture. The display shows "ON" or "OFF". Press "Enter" to confirm.

Temp.Info

With this function you can display the different temperature of the fixture.

- L: Light engine
- B: Base
- H: Head

Humidity

With this function you can display all the different humidity values available in the fixture.

- B: Base
- H: Head

Fan Info.

With this function, you can display all the fan speed values available in the unit.

Software Ver

With this function, you can display the software version of the device.

Signal Quality

When IOT Board is connected, this menu shows the signal quality (Wifi/4G).

Network

With this function, you can display the Network information.

Error Info

With this function, you can Read the error record of the Unit

Blackout Info

With this function, you can display the Blackout information.

SN

With this function, you can display the serial number of the Unit.

RDM UID

With this function, you can display the RDM UID of the Unit.

3.7.5 Test

Home

With this function you can reset the device. You can select which functions you want to reset by using the submenu.

Test Channel

With this function you can test each channel's function to ensure correct operation.

Manual Control

Allows you to manually control each feature of the unit.

Calibration

With this function, you can calibrate and adjust the effect wheels to their correct positions. The password of calibrate values is 050.

CMY Comp

With this function, you can calibrate and adjust the CMY compensation values.

Gobo Replace

This function allows you to select the gobo you want to replace. The chosen gobo will be rotated into position, making it easy to swap out.

3.7.6. Preset

Run the auto program: A main fixture can output to three different program signals to the follow fixture to operate. It means the host will send cyclically in the following orders (The host will keep operating the program of Part 1). Then the follow fixture will make the selectively receiving according to its own set.



- If the follow fixture chooses Run For Follow 1 from the menu of 1-3, then it will receive the part 1's automatic program from link, in the same way, when the follow fixture chooses Run For Follow 2, then it will receive the part 2's automatic program from link.
- Enter the menu of 1-3 Function Mode---Set To Follow. Here to set machine operate which part of the program during the host-follow connection.
- Enter the menu of 1-4, 1-5 Function Mode---Set To Main.
- Enter the menu of 8-1 Edit Program---Auto Program Part1. The host outputs three groups driven program---Part1, Part2, Part3 (Part1 program runs the same effect as the host).
- Enter the menu of 8-2 Edit Program---Edit Program. Edit the program's connection, connect the scene in order.
- The editor of the scene, there are as many as 250 scenario editors, and every scene can have a program connection of 10.

Note:
Part 2, Part 3 repeat in accordance with the Part1's repeat. For example: When Part 1 uses Program 2, Part 2 uses Program 4, Part 3 uses Program 6, Assume: Program 2 includes scene of 10, 11, 12, 13. Program 4 includes scene of 8, 9, 10; Program 6 includes scene of 12, 13, 14, 15. Then it will run as below.

Example:

Part 1:



Part 2:



Part 3:



3.7.7. Shortcut Menu

Flip display

With this function you can rotate the display by 180° (when the unit is rigged)

Restore Factory

With this function, you can restore default setting (highlighted value in the above chart).

Restore Options

This function restores only the altered options settings (highlighted values in the chart above) to their default state.

Restore User

With this function, you can restore User settings (Setting can be edit under Options/Reset User Set).

Rst DMX addr 1

With this function you can only set the address to 1.

Product SN

With this function, you can display the serial number of the Unit.

Laser SN

With this function, you can display the serial number of the Laser.

RDM UID

With this function, you can display the RDM UID of the Unit (Also QRCode).

Pressure

Under this menu, you can manage the pressure of the Unit :

- Pressure Test : Under this menu you can Run the Pressure test
- Test Result : Under this menu you can display the result of the last pressure test
- Head/Base Pres : Under this menu you can display the value of the Head and Base Pressure

Unlink WDMX

This function allows you to disconnect the fixture from its current WDMX transmitter.

3.8 › NFC

When the fixture is powered on, you can use a NFC smartphone installed with the Ayrton NFC App to scan the NFC tag area of the fixture to read some of the information or settings inside the display menu, such as product name, software version, UID, DMX Start Address, Universe, User Mode, Options, Information, etc. You can also change some of the settings and push to write inside the fixture menu.

When the fixture is not powered on, you can still use the App to read the NFC info and write the settings into the NFC tag, the written

data will be automatically synchronized into the fixture menu at next time the fixture is powered on.

Link to download the application: <https://qrstud.io/ayrtonnfc>

Note:

- Before using, make sure there is NFC function on your smartphone and it is activated. Download and install the Ayrton NFC App;
- The NFC tag on the fixture is right under the LCD window;
- The NFC reader area vary on different smartphones, identify the correct area on your smartphone before scanning the NFC tag on the fixture;
- When scanning, make sure the NFC reader area of your smartphone close enough to the LCD window and hold still the smartphone for 3 seconds until reading successfully.

3.9 > DMX PROTOCOL

Scan the QR code on the cover page to download the DMX CHART.

3.10 > SAFETY SETTINGS

For safety purposes, before the operator begins to control the fixture remotely, the operator must pre-define, from a computer (MAC or PC) App a safety (blanking) zone which prevents operations above the MPE (Maximum Permissible Exposure) within the safety zone(or other). The safety (blanking) zone should be set to include any area in which the fixture may be pointed where there is a reasonable expectation of the public being present. Where the operator determines there will be no members of the public present or no members of the public present within the Hazard Distance of the product (please see table below), no safety (blanking) zone is needed to be set.

US HD (United States Hazard Distance) = TBA
 Non US HD = 48.7 meters (157.48 feet).
 Hazard Distance (worst case) is measured at full power and narrowest beam angle for 0.25 seconds.
 However, do not illuminate personnel closer than this distance under any circumstances.

BLANKING ZONE SETTINGS

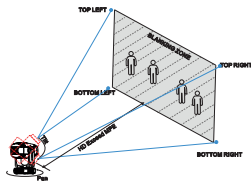

Steps to set blanking zone: please refer to the "Blanking zone setting guide"

SAFETY PROTECTION

This fixture had been designed with Safety Protection feature: When error occurs, not only the light output itself will be cut immediately, but also the CMY filters, Colour filter and Frost filter will be brought into the light path and the Zoom will go to max immediately to block the light output lens to provide multi-protection layers.

SAFETY MONITORING SYSTEM - SEPARATE REDUNDANCY CONTROL

This fixture had been designed with a Safety Monitoring System with Separate Redundancy Control, the failure safety system shuts down or dims to safe level immediately when any safety monitored value is reported outside of expected value: When light output (as measured by current) is out of expected range; when Pan or Tilt are forced from proper location, or do not arrive at proper location; when zoom is

forced from proper location, or do not arrive at proper location.

HEAD COVER OPENING AND CLOSING PROCEDURE

To ensure that the cover is pressed evenly all around the seal, we recommend following the attached tightening order:

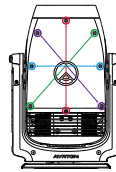

- Check the seal, it must be clean and undamaged, properly seated to avoid any damage when tightening.
- First lightly tighten the screws into position and then tighten with a torque screwdriver.

Torque value : 14Kgf.cm for metal cover or 7Kgf.cm for plastic cover.

4. CONTROLS AND FUNCTIONS

4.1 > PAN AND TILT MOVEMENT, DMX CHANNELS 1-7

4.2 > DIMMER INTENSITY (USE WITH STROBE CHANNEL AT FULL), DMX CHANNELS 9-10



4.3 > ZOOM (USE WITH FOCUS CHANNEL), DMX CHANNELS 14-20

Beam Mode

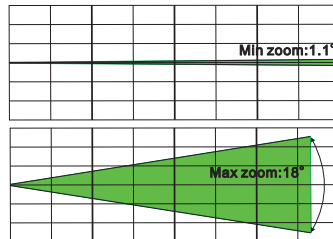

Spot Mode

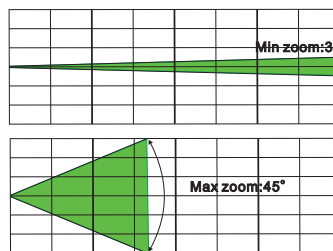

4.4 > CTO, CMY, DMX CHANNELS 11-12, 23-28



4.5 > COLOUR WHEEL WITH CTO, DMX CHANNELS 21-22

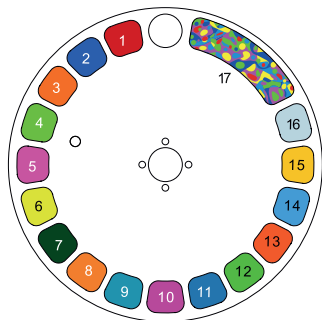

COLOUR WHEEL

1	Red	10	Follies Pink
2	Blue	11	Slate Blue
3	Orange	12	Lime
4	Green	13	Dark Amber
5	Pink	14	Medium Blue
6	Yellow	15	Oklahoma Yellow
7	Velvet Green	16	CTB
8	Amber	17	Colour animation
9	Light Blue		

4.6 > ROTATING GOBOS, DMX CHANNELS 29-31

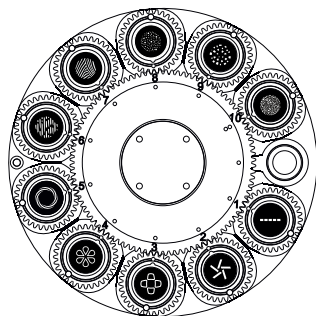

GOBO WHEEL 1

Rotating Gobo

1	364	Rectangle Line 5	6	278	Bread Stix
2	344	Star Bar 5	7	096	Zebra
3	186	Game Pad Stroke	8	075	Starfield
4	264	Daisy Stroke	9	070	Circle of Squares
5	112	Nested Rings	10	101	Deep Forest

4.7 > STATIC GOBOS, DMX CHANNELS 32

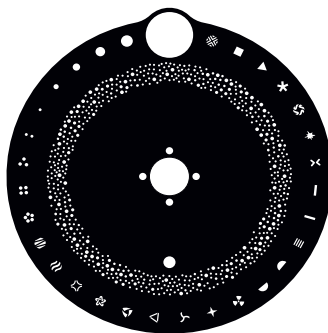

GOBO WHEEL 2

Static Gobo

1	302	80% Iris Beam	16	374	Compass 4
2	304	60% Iris Beam	17	149	Nuclear
3	306	40% Iris Beam	18	299	Half Beam Right
4	307	30% Iris Beam	19	298	Half Beam Left
5	308	20% Iris Beam	20	353	Four Lines H
6	312	Dot Line 2	21	350	Bold Line
7	326	Dot Triangle 3	22	351	Vertical Line
8	328	Dot Square 4	23	437	Split Cross
9	319	Dot Ring 5	24	270	Ink Stain 2
10	257	Zig Zag Light	25	439	Circulaw Saw 4
11	099	Waves Light	26	394	Starfield Light
12	419	Iron Ball Light	27	340	Triangle Beam
13	373	Nested Star	28	330	Square Beam
14	261	Arrow Ring 3	29	435	Nest Cross
15	117	Helix 3			

4.8 > PRISMS (WITH FROST), DMX CHANNELS 33-38

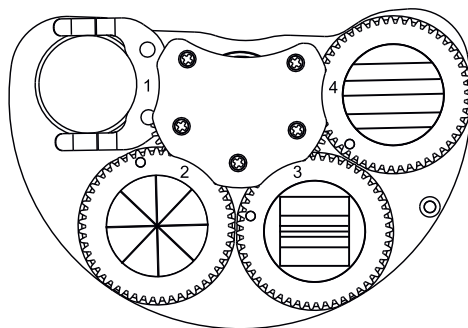

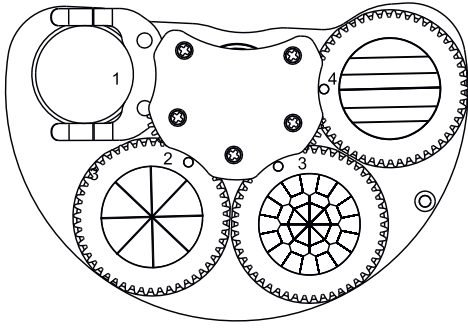



AYRTON

Digital Lighting

